

BAK-Q80 / BAK-Q60 Fuel filler security connection and configuration

Introduction

This user guide describes how to connect and configure the BAK-Q80 / BAK-Q60 fuel filler security module. This fuel filler security features an anti-theft strainer that will block access to the fuel tank via the filling hole, while not obstructing the fuel flow when refilling. The main feature of this fuel filler security is the lock/unlock state reading via digital input. When configured, the FM device will send the current fuel filler state to the server.

This module is compatible with these FM devices:

- HCV5
- LCV5
- Pro5
- FM-Tco4 HCV
- FM-Tco4 LCV
- FM-Pro4
- FM-Eco4
- FM-Eco4 S

You can get the latest firmware and configurator from our documentation website: doc.ruptela.it

Legal notice

Copyright © 2020 Ruptela. All rights reserved. Reproduction, transfer, distribution or storage of parts or all of the contents in this document in any form without the prior written permission of Ruptela is prohibited. Other products and company names mentioned in this document are trademarks or trade names of their respective owners.

Document change log

Date	Version	Change details
2017-08-24	1.0	Initial draft.
2018-11-15	1.1	Compatible device list updated.
2020-10-23	1.2	Updated: Compatible device list, connection schematic. Added: 5 th gen connection schematic.

Description

BAK-Q80 / BAK-Q60 is a fuel filler security module used for protecting the fuel tank from theft or sabotage. It consists of a plug module and an anti-theft strainer module. It works by monitoring the presence of the transponder, situated in the fuel plug over the plug module.

The plug module can be connected to the FM device via the DIN connector (See schematic below). When configured, information whether the fuel tank is opened or closed will be sent to the server. The fuel filler security works as follow:

If the fuel tank is opened, the system interprets it as a change in output state and this information is sent to the server.

The anti-theft strainer module consists of a pipe with perforated walls and bottom. The shape of the bottom and the holes has been designed as not to obstruct the fuel filling operation, while at the same time it protects from fuel theft.

Mounting instructions

The fuel filler security module must be installed by following these steps:

1. Unscrew the original plug from the fuel filler.
2. Degrease the tank fuel filler and the flange of the plug module using a cloth supplied in the assembly kit.
3. Put silicone onto the fuel filler and the flange of the plug module.
4. Put a seal onto the flange of the plug module.
5. Mount the plug module along with the seal onto the fuel filler, turn the screw clockwise until it is tightly screwed. It is recommended to use a flange in order to prevent the plug module cable from sticking outside the vehicle.
6. Carefully drill a $\varnothing 4$ mm hole through the mounting holes in the filler.
7. Put the mounting sleeve onto the removable rivet and place it in the riveter. Rivet both holes.
8. The cable must be protected by using a protective pipe, which must be tightened on the flange of the plug module housing. For this step, use a cable tie. Guide the cable to your FM device in such a way that all possible thermal and mechanical damage caused by day-to-day use of the vehicle is minimal.
9. Thread the seal line with beads through the seal holes and tie it around the protective pipe. Seal it.
10. Put silicone into the mounting holes and push the rubber caps inwards.
11. Cut away the protruding cap parts.
12. Screw the plug in the plug module and do it again several times to check if the plug module was assembled onto the fuel tank correctly.
13. Put the plug cover on the plug module and tighten the string. Ensure that the plug cover fully sticks to the fuel filler. Secure the loose string.



Connection to the tracking device

In order to track the fuel filler state your tracking device should be connected to the plug module as follows:

Advanced Family devices:

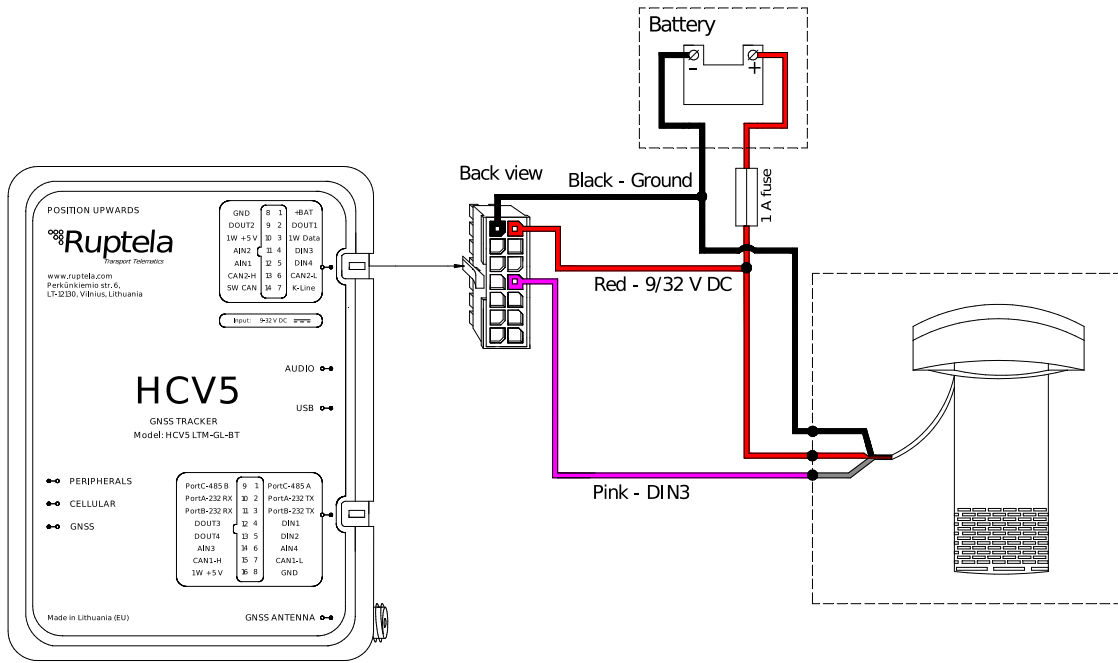

Pro Family devices:

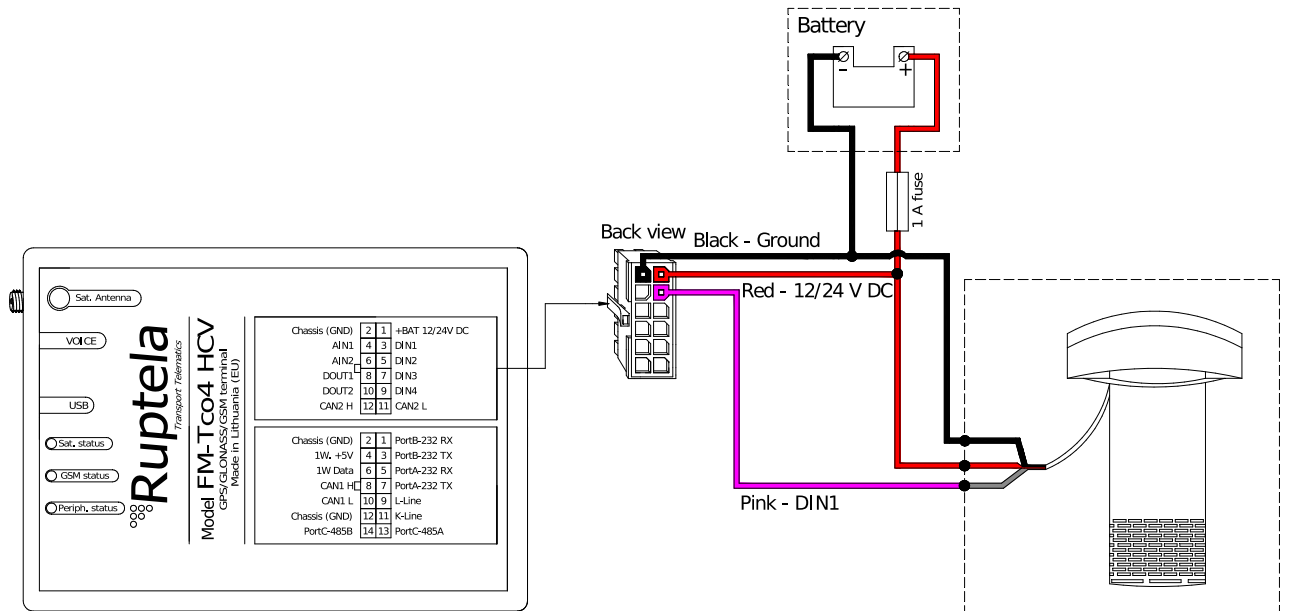

Configuration

1. In the main configurator window choose your device.
2. In the **I/O events** section click on the "Options" button.
3. Select a slot that you want to enable.
4. In the **IO properties** section tick the **Enable** check box, otherwise the slot will remain empty.
5. **ID** contains the parameters list. Choose a parameter you want to enable for the selected slot. For the plug module that was connected to the 1st digital input you should enable "DIN1" IO parameter.
6. It is recommended to set record generation with **Event on Change** and **Priority High**. This way you will get notifications about DIN1 status changes as soon as they happen.

Once all the steps are complete, you should be able to track fuel cap status (closed/opened). DIN1 state will be shown in TrustTrack reports (opened: 1 and closed: 0)

