

# RS232 Camera

User Manual

# Table of Contents

1	Introduction .....	3
1.1	About the Functionality .....	3
1.2	Legal Information .....	3
1.3	Compatibility .....	3
1.4	Contact Information.....	4
1.5	Document Changelog.....	4
1.6	Notations.....	4
1.7	References.....	5
2	Principles of Operation.....	6
3	Connection .....	7
3.1	Connection of One RS232 Camera .....	7
3.1.1	Connection to 5 <sup>th</sup> Generation Advanced Family Devices .....	7
3.1.2	Connection to 4 <sup>th</sup> Generation Advanced Family Devices .....	8
3.2	Connection of Two RS232 Cameras.....	9
3.2.1	Connection to 5 <sup>th</sup> Generation Advanced Family Devices .....	9
3.2.2	Connection to 4 <sup>th</sup> Generation Advanced Family Devices .....	10
4	Configuration.....	11
4.1	Starting the Configuration .....	11
4.2	Configuring the RS232 Camera .....	12
4.3	Finishing the Configuration.....	15
5	Picture Request via SMS .....	16

# 1 Introduction

## 1.1 About the Functionality

RS232 cameras can be used for various surveillance applications, for example, to identify people inside the cabin, to monitor driving conditions, to monitor the cargo, to know what happened in case of emergency, etc. Two cameras may be used with the tracking device, allowing the user to surveil several parts of the vehicle at the same time.

This feature description applies to tracking devices with the latest firmware version.

You can get the newest firmware and configurator from our documentation website: [doc.ruptela.it](http://doc.ruptela.it)

## 1.2 Legal Information

Copyright © 2020 Ruptela. All rights reserved. Reproduction, transfer, distribution or storage of parts or all of the contents in this document in any form without the prior written permission of Ruptela is prohibited. Other products and company names mentioned in this document are trademarks or trade names of their respective owners.

## 1.3 Compatibility

The RS232 camera is compatible with the following devices with the newest firmware version:

- HCV5
- LCV5
- Pro5
- FM-Tco4 HCV
- FM-Tco4 LCV
- FM-Pro4

## 1.4 Contact Information

### General enquiries

Website: [ruptela.com](http://ruptela.com)

E-mail: [info@ruptela.com](mailto:info@ruptela.com)

Phone: +370 5 2045188

### Technical support

E-mail: [support@ruptela.com](mailto:support@ruptela.com)

Phone: +370 5 2045030

## 1.5 Document Changelog

Version	Date	Modification
1.0	2018-08-02	Initial draft.
1.1	2018-09-11	Compatible models described. Link to the manufacturer's website added.
1.2	2019-02-15	Added description of "Last snapshot info" IO event. Note regarding SD card insertion added.
1.3	2020-05-18	Removed description of "Last snapshot info" IO event.
2.0	2020-07-01	Updated: Principles of operation. Updated: Manual design and structure.
2.1	2020-07-16	Updated: Connection schematics.

## 1.6 Notations

The following notations are used in this document to highlight important information:

### **Bold text**

Used to indicate user interface elements or for emphasis.

### *Italic text*

Used to indicate items that belong to a list and can be selected.

### **Note**



Used to highlight important information or special conditions.

### **Tip**



Suggestions on how to proceed.

## 1.7 References

Datasheet: <https://doc.ruptela.lt/pages/viewpage.action?pageId=884778>

## 2 Principles of Operation

RS232 cameras can be configured to take pictures at regular intervals, during configured events or on demand via an SMS command. If the tracking device has an SD card, the pictures will be stored in the card and sent to a server upon request. If the camera folder on the SD card is full, the oldest picture will be overwritten. If the folder is full and there are no pictures on the card, the taken picture will be discarded. After receiving the pictures, the server can then send a request to delete them from the SD card to conserve memory. A maximum of 2000 pictures can be stored in the camera folder.

If the tracking device does not have an SD card, one picture will be stored. No other pictures will be taken until the server sends a request to delete the picture.



If you insert/remove the SD card, the tracking device should be restarted to ensure the correct operation.



Every time after the start/restart of the tracking device, a GPS fix must be obtained to automatically synchronize time with the RS232 camera.

# 3 Connection

## 3.1 Connection of One RS232 Camera

### 3.1.1 Connection to 5<sup>th</sup> Generation Advanced Family Devices

Connect the RS232 camera to your tracking device as follows (Port A is used in this schematic):

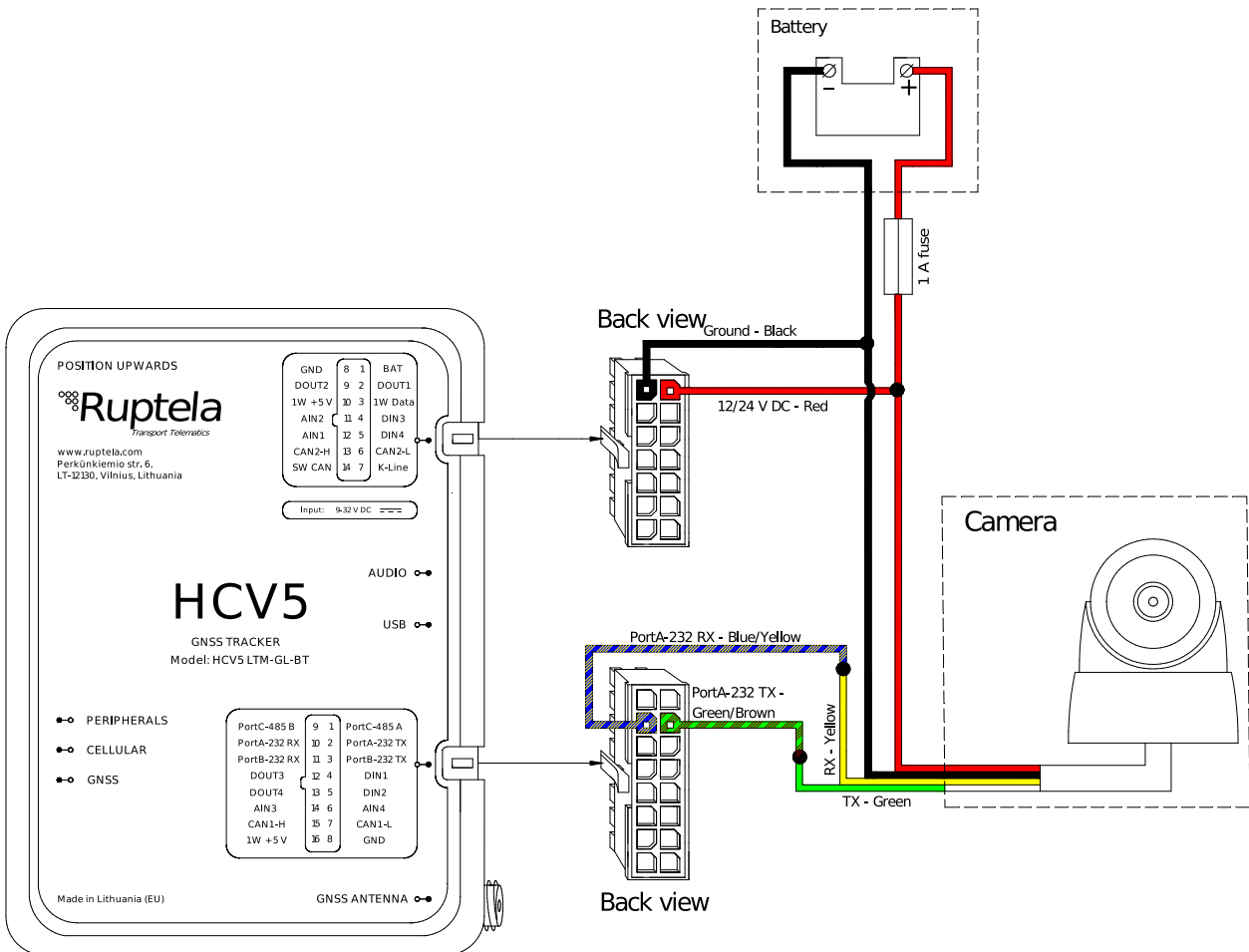

**i** Alternatively, TX and RX wires can be connected to Ports B (16 pin connector, pin 3 and 11, pink/green wire, red/cyan wires).

### 3.1.2 Connection to 4<sup>th</sup> Generation Advanced Family Devices

Connect the RS232 camera to your tracking device as follows (Port A is used in this schematic):

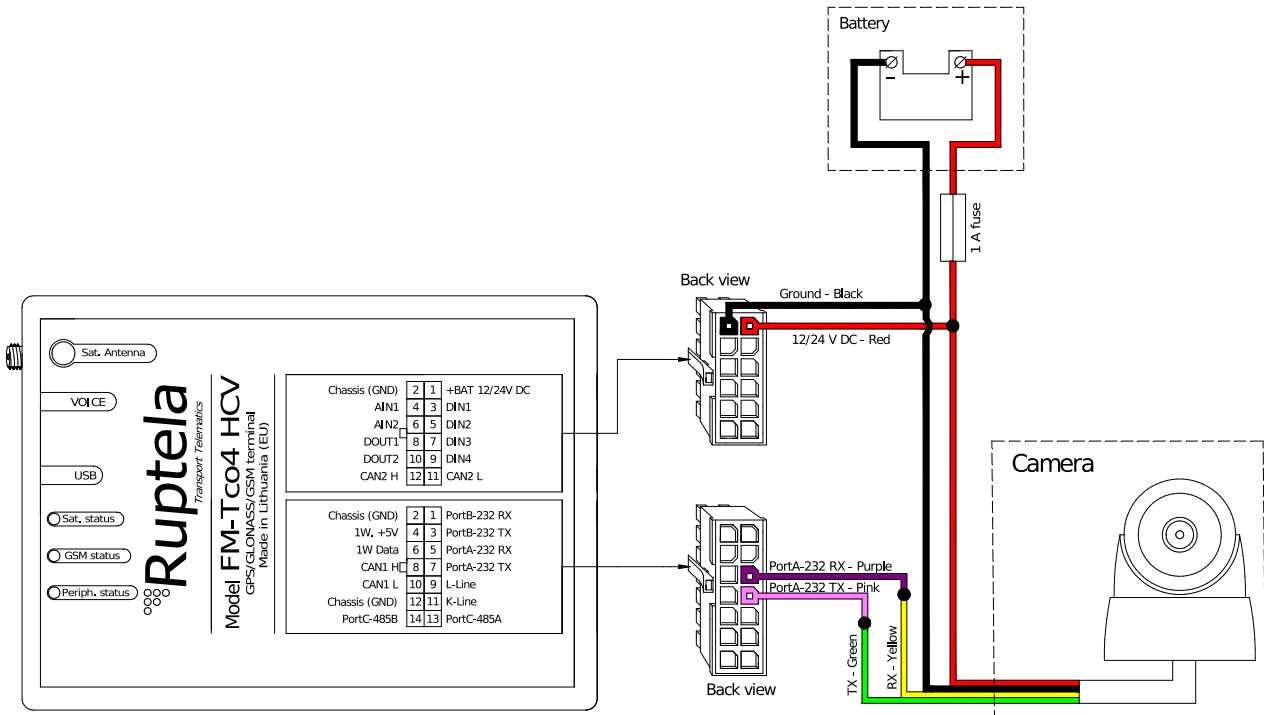

Alternatively, TX and RX wires can be connected to Port B (14 pin connector, pin 3 and 1, orange and yellow wires).



## 3.2 Connection of Two RS232 Cameras

### 3.2.1 Connection to 5<sup>th</sup> Generation Advanced Family Devices

Connect the RS232 cameras to your tracking device as follows:

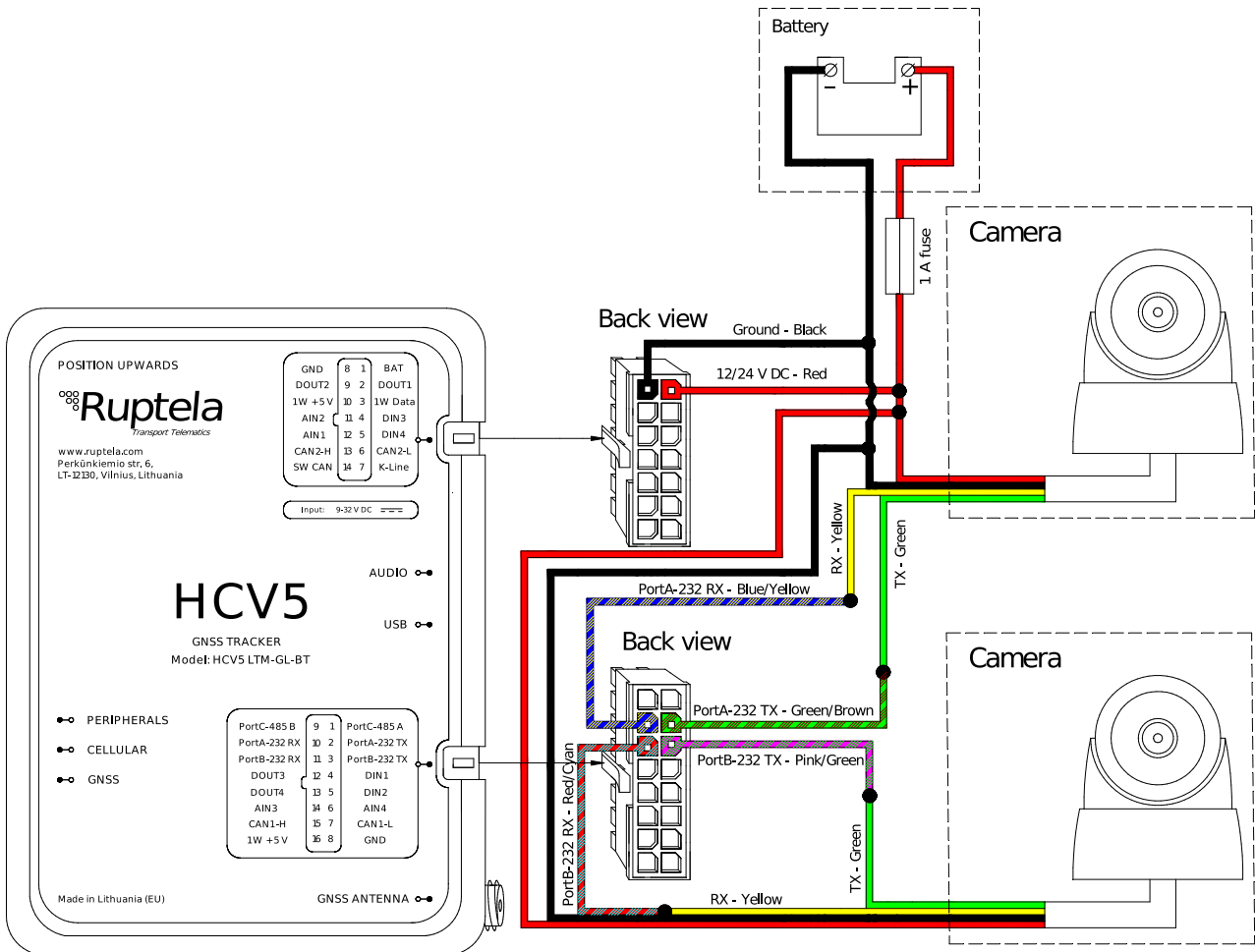

### 3.2.2 Connection to 4<sup>th</sup> Generation Advanced Family Devices

Connect the RS232 cameras to your tracking device as follows:

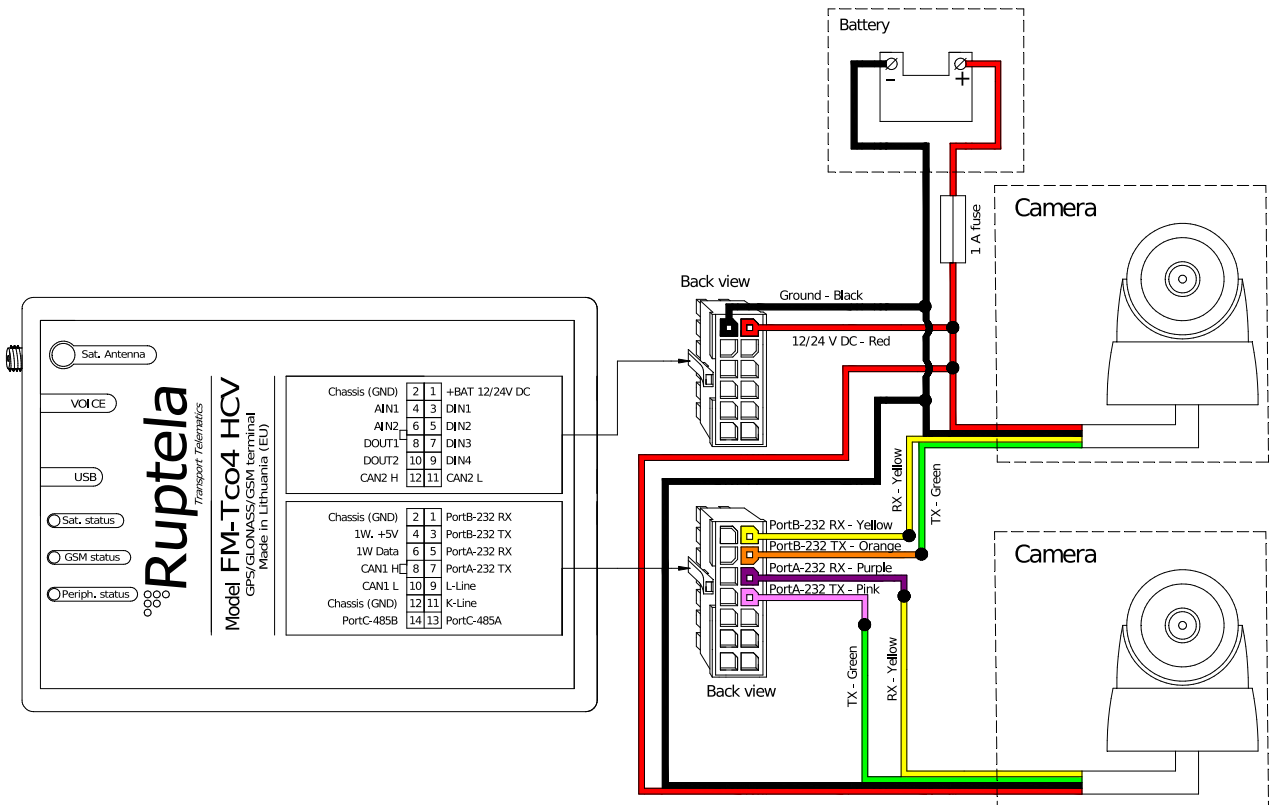

# 4 Configuration

**i** This functionality requires the use of the advanced configurator.

## 4.1 Starting the Configuration

To start the configuration, follow these steps:

1. Open the advanced configurator. Select your tracking device.
2. Select the COM port to which your device is connected.
3. Click **Connect**.
4. Click the **Options** button in the **IO events** section to open the **IO Settings** window.

The screenshot shows the advanced configurator interface with several elements highlighted by red boxes and numbered callouts:

- COM7** (2): A red box highlights the COM port selection dropdown.
- Connect** (3): A red box highlights the Connect button.
- Too4 HCV** (1): A red box highlights the device selection dropdown.
- Options** (4): A red box highlights the Options button in the IO events section.

The interface includes sections for Global settings (Protocol, APN settings, Connection settings), Authorized numbers, Eco-Drive, Authorized IDs, Audio settings, Movement sensor sensitivity, GNSS selection, Geofencing, Towing detection, Impact detection, Identification string, and Profile settings (Sleep, Data sending, Data collection, 2G-3G, Operator list, IO events).

## 4.2 Configuring the RS232 Camera

Follow these steps to configure the RS232 camera:

1. Tick the **Send I/O data with v1.1 protocol** checkbox.
2. In the **Interfaces** section select the port, to which the RS232 Camera is connected (*PortA* or *PortB*).
3. Select *Camera* from the drop-down list.
4. Click **Config** to open the **Camera A configuration** or **Camera B configuration** window.
5. Select the picture resolution. Default value: *320x240*.
6. If you want the camera to take pictures at regular intervals, tick the **Capture by interval** checkbox. Default value: disabled, *5*.
7. Select the picture compression rate with the **Data compression** slider. Moving the slider towards *File size* will decrease picture file size and quality while moving it towards *Quality* will increase picture quality as well as file size. Default value: *Balanced*.
8. Select the exposure level with the **Exposure level** slider. Default value: *0.0*.

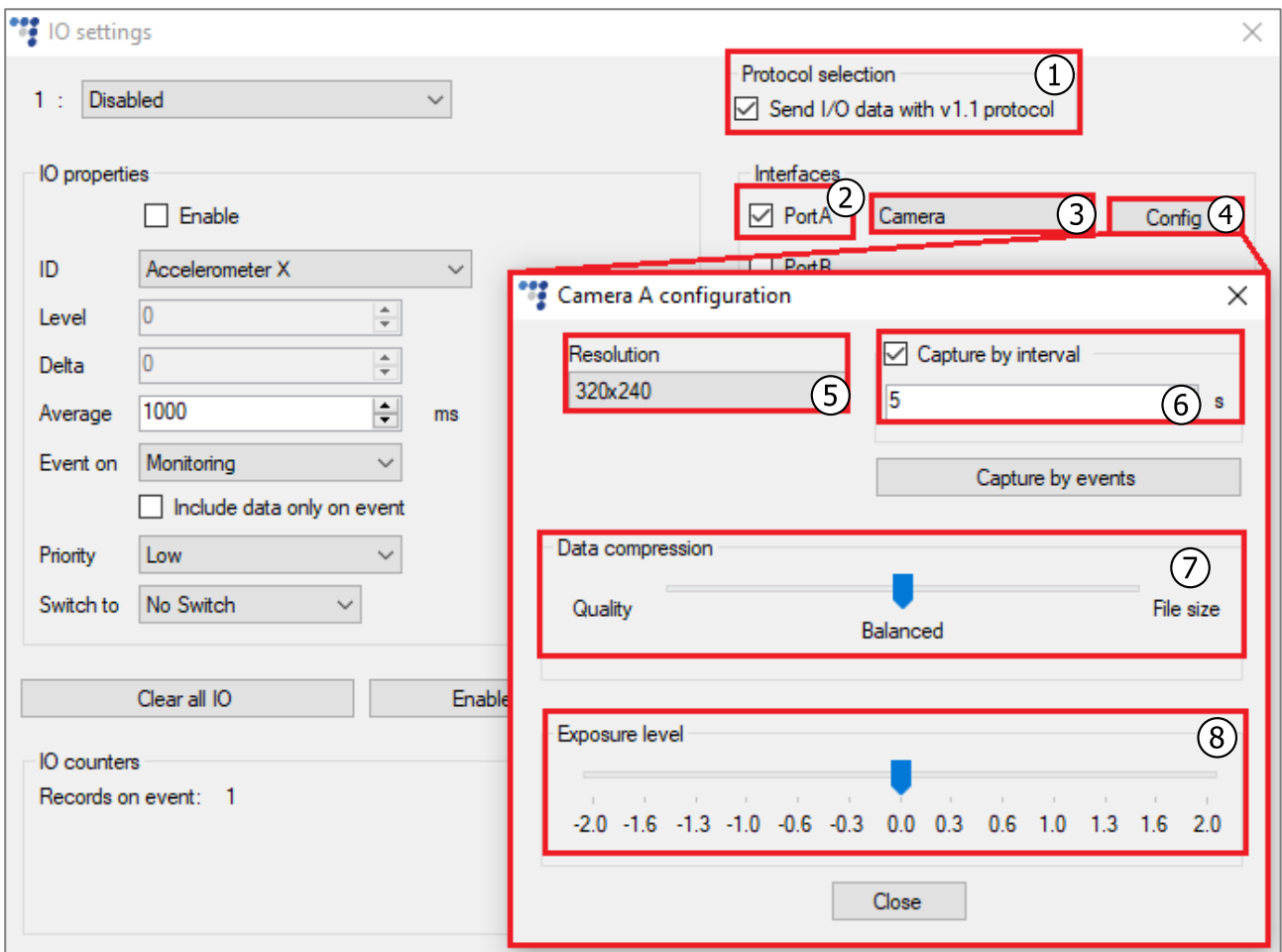

9. If you want the camera to take pictures when specific IO events are triggered, click the **Capture by events** button to open the **Camera A event settings** or **Camera B event settings** window.
10. Select the required events by ticking the checkboxes. Click **Save**.
11. If you have two connected cameras, repeat steps 2-10.



Make sure that the events are enabled and properly configured in the active profile. Events that are not enabled/configured will be marked in red, and trying to select them will cause a pop-up warning message to appear.

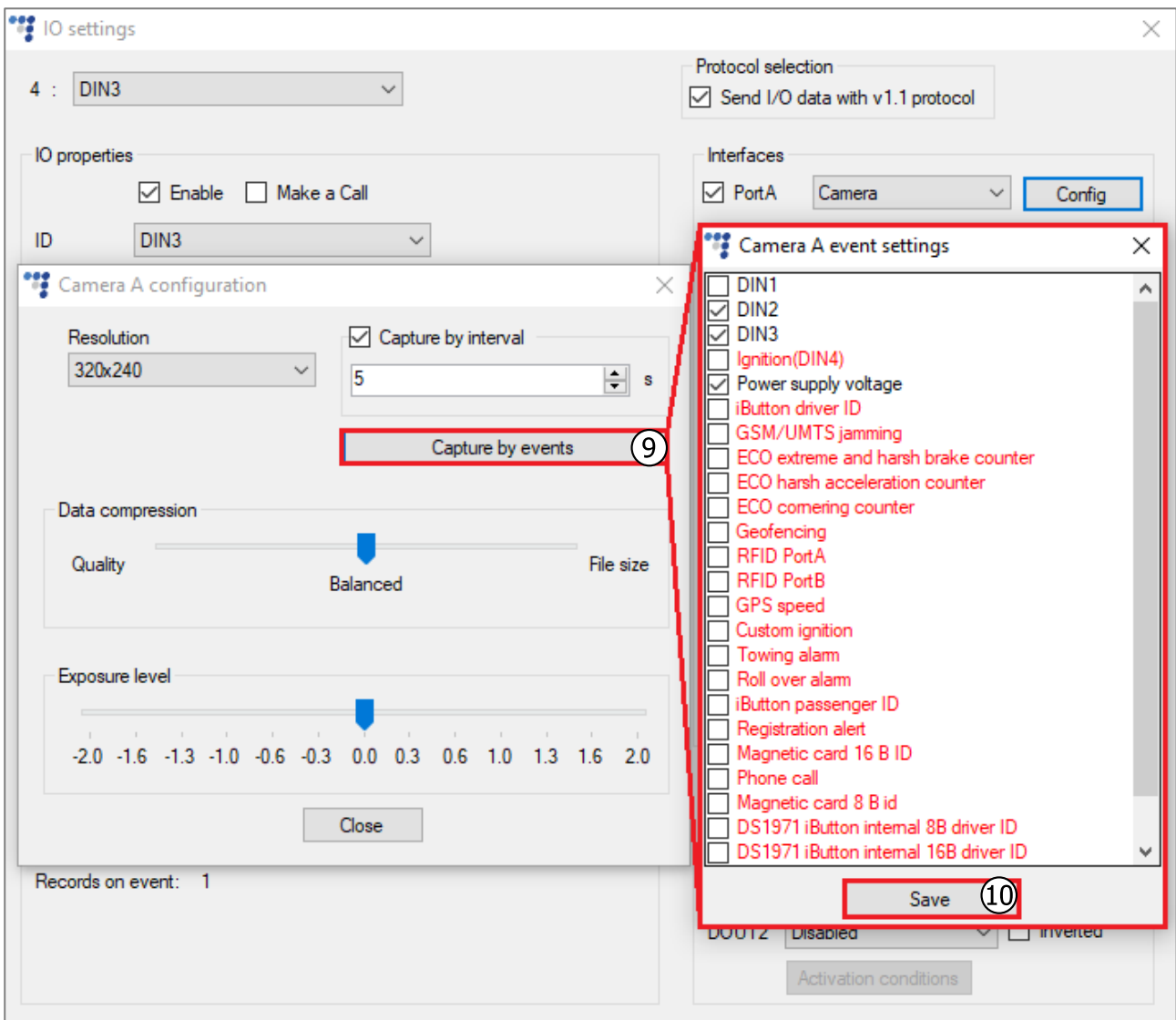

The following table shows the IO events, which must be configured to inform the server how many pictures were taken since the last record and are stored in the SD card:

Event name	Monitoring	On Change	On Hystersis
PortA camera snapshot on SD card	+	+	+
PortB camera snapshot on SD card	+	+	+

The following table shows the IO events, which must be configured to inform the server when there is a picture in camera memory:

Event name	Monitoring	On Change	On Hysteresis
PortA camera snapshot	+	+	+
PortB camera snapshot	+	+	+



You can use the **Enable IO** button to automatically enable the camera snapshot on SD card and camera snapshot events on a serial port.

The following table shows the **Event on** settings for various IO events required to be configured:

Event name	On Change	On Hysteresis
DIN1	+	+
DIN2	+	+
DIN3	+	+
Ignition(DIN4)	+	+
Power Supply voltage		+
iButton driver ID	+	+
GSM/UMTS jamming	+	+
ECO extreme and harsh brake counter	+	
ECO harsh acceleration counter	+	
ECO cornering counter	+	
Geofencing	+	
RFID PortA	+	+
RFID PortB	+	+
GPS speed		+
Custom ignition	+	+
Towing alarm	+	+
Roll over alarm	+	
iButton passenger ID	+	
Registration alert	+	
Magnetic card 16 B ID	+	
Phone call	+	
Magnetic Card 8 B ID	+	+
DS1971 iButton internal 8B driver ID	+	+
DS1971 iButton internal 16B driver ID	+	
DS1971 iButton internal 8B passenger ID	+	+
DS1971 iButton internal 16B passenger ID	+	

## 4.3 Finishing the Configuration

To finish the configuration, close the **Camera A configuration** and **IO settings** windows. Click **Send CFG** to send the configuration to the device.

The screenshot displays the Ruptela configuration software interface. At the top, there is a 'Configuration file information' section with fields for 'Configuration source: Configurator', 'Target device: n/a', 'FM device FW version: n/a', 'CFG Tag: [input field]', 'FM4 Configurator version: n/a', and 'Last edited: n/a'. The Ruptela logo is visible in the top right corner.

The main interface is divided into several panels:

- Global:** Includes a 'COM8' dropdown, a 'Disconnect' button, and a 'Send CFG' button (highlighted with a red border). Other buttons include 'Get CFG', 'Send FW', and a 'Tco4 LCV' dropdown.
- Protocol:** Radio buttons for 'UDP' (selected) and 'TCP'.
- APN settings:** Fields for 'Name', 'User', and 'Psw'. Checkboxes for 'Lock FM device to the SIM card' and 'AutoAPN' with an 'Options' button.
- Connection settings:** Fields for 'IP1', 'Port1' (0), 'IP2', and 'Port2' (0). Checkboxes for 'SSL 1', 'SSL 2', 'Two servers', and 'SSL client authentication'. Buttons for 'Periodical redirect' and 'SSL settings'.
- GNSS:** 'GNSS selection:' dropdown set to 'GPS+GLONASS'.
- Geofencing:** An 'Options' button.
- Authorized numbers:** An 'Options' button.
- Eco-Drive:** A checked 'Enable' checkbox with an 'Options' button.
- Authorized IDs:** A checked 'Enable' checkbox with an 'Options' button.
- Audio settings:** An 'Options' button.
- Movement sensor sensitivity:** A slider ranging from 1 (Min) to 10 (Max), with the marker currently at 8.

## 5 Picture Request via SMS

The user can take pictures on-demand with the *snapshot* SMS command, using the following structure: *password snapshot <camera number>*

*<camera number>* can have the following values:

- *0* – the command applies to all configured cameras;
- *1* – the command applies to the camera configured on PortA;
- *2* – the command applies to the camera configured on PortB.

After sending the SMS command, the tracking device will send a response, using the following structure: *snapshot <camera number> <answer>, <other camera number> <answer>*

*<answer>* can be one of the following:

- *ok* – indicates that the camera took a picture successfully;
- *busy* – indicates that the camera is busy with a previously taken picture at the moment;
- *n/a* – indicates that the camera is either not configured on the given port, not connected or not responding;
- *fullsd* – indicates that the memory of the SD card is full and the picture will be discarded, as there are no pictures to be overwritten;
- *err* – indicates that there was an error.

### Example 1

Request:

*password snapshot 1*

Response:

*snapshot 1 ok*

### Example 2

Request:

*password snapshot 0*

Response:

*snapshot 1 ok, 2 n/a*