

Trailer identification using 1-Wire temperature sensor

Introduction

1-Wire temperature sensor can be used to assign a unique ID to a trailer. Two FM devices are required for this. Identification is achieved by installing the sensor in the trailer, connecting it to an FM device installed in the truck and installing an additional FM device in the trailer. The entire process is described step by step in this document.

This trailer identification method can be used on any device that supports the 1-Wire interface:

- FM-Tco4 HCV
- FM-Tco4 LCV
- FM-Pro4
- FM-Eco4
- FM-Eco4 S

You can get the latest firmware and configurator versions from our documentation web site doc.ruptela.it

Legal information

Copyright © 2019 Ruptela. All rights reserved. Reproduction, transfer, distribution or storage of parts or all of the contents in this document in any form without the prior written permission of Ruptela is prohibited. Other products and company names mentioned in this document are trademarks or trade names of their respective owners.

Document change log

Date	Version	Change details
2017-03-30	1.0	Initial draft.
2018-11-15	1.1	Compatible device list updated. Configuration example updated.
2019-01-18	1.2	Installation requirements clarified.

Installing the 1-Wire temperature sensor

Before installing the temperature sensor, make sure both FM devices in truck and trailer are installed. It is recommended to use a device with an internal battery in the trailer as not all trailers may have a separate power supply.

The temperature sensor must be installed in the trailer and connected to the ISO3731 connector. The sensor installation location has low importance, but standard technical and electrical safety measures must be considered during the installation. This means that all the wiring must be installed out of reach of moving and heat radiating trailer parts. The wires must be firmly fixated with the use of cable ties, without the chance of them going loose.

Since the temperature sensor will be used for identification purposes only, it is recommended to install it close to the ISO3731 connector. The installation place should be evaluated individually for every trailer, taking into account structural differences from each manufacturer.

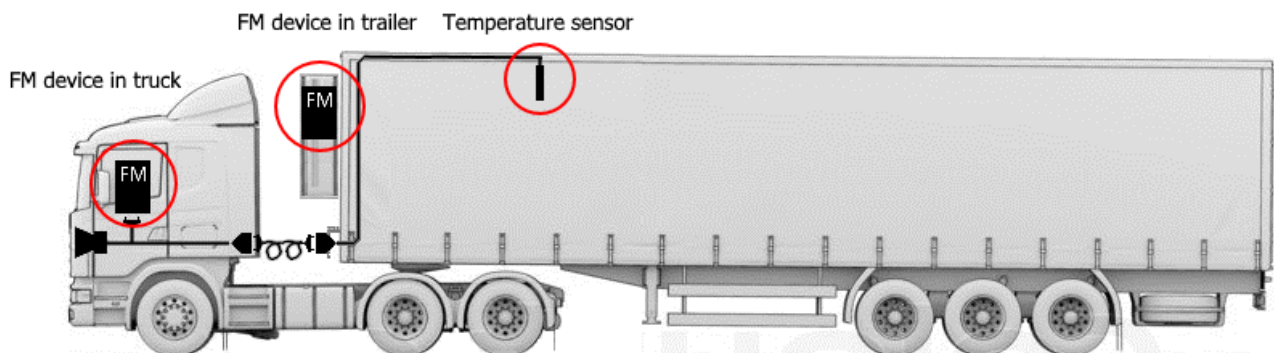

After installing the temperature sensor, it is necessary to connect it to the ISO3731 connector. This connector is usually located at the front part of the trailer (side that connects to the truck). Depending on the trailer manufacturer, individual structure or modifications, the presence and location of the ISO3731 connector may differ.



Shown below is the connection schematic of the temperature sensor to the ISO3731 connector.

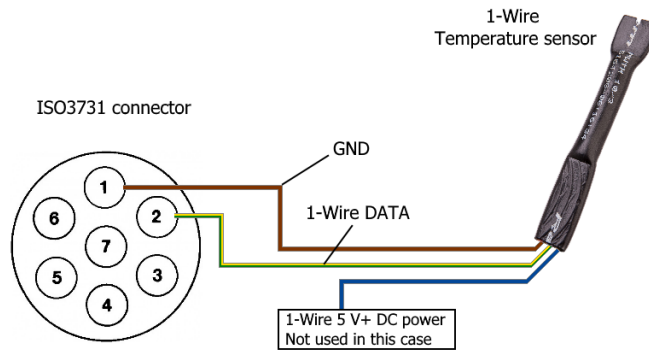

Temperature sensor to the ISO3731 connector wiring:

From the ISO3731 side	From the temperature sensor side
Not used	Blue – 1-Wire power 5 V DC
Pin 2	Green/Yellow – 1-Wire DATA
Pin 1	Brown – GND

Important!

The pins of the ISO3731 are numbered from the **internal** side, this must be taken into account when connecting the wires. This means the pins numbers match when looking at the connector from the inside (disassembled).

Note

It is recommended to connect the 1-Wire temperature sensor fully, including the power pin. Otherwise, the sensor may not work correctly.

Connection from the trucks' cabin side

This manual assumes an installed ISO 12098 connector on the cabin side. The connector on the trailer and the connector on the cabin are connected using an air cable shown below.



In most cases the ISO 12098 connector is located on the rear part of the trucks' cabin (side which connects to the trailer). Depending on the cabins' manufacturer, individual structure or modifications, the presence and location of the ISO12098 connector may differ.



The wiring to the ISO 12098 connector may differ depending on the truck manufacturer. Two examples are provided (based on client experience).

Scania

In the example shown below, a black-white wire is connected to the 11th pin on the ISO 12098 connector. This wire goes through the cabin, and is not used by the manufacturer, this allows connecting it to the FM device.

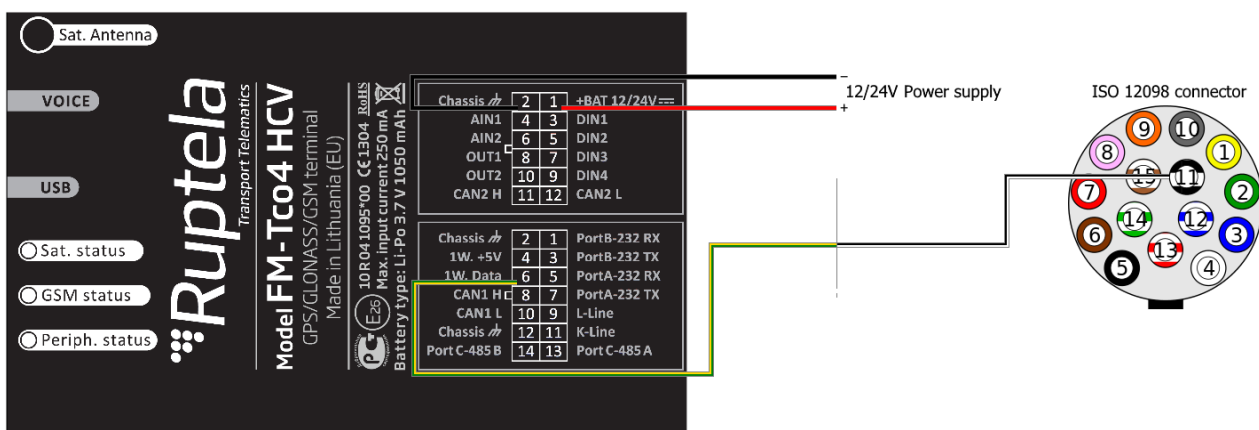

From the FM device side
1-Wire Data

From the ISO12098 connector side
Black/White – 1-Wire data from the temperature sensor

Important!

The pins of the ISO12098 are numbered from the **internal** side, this must be taken into account when connecting the wires. This means the pins numbers match when looking at the connector from the inside (disassembled).

Renault

In the case with this manufacturer there is no wire connected to the 11th pin of the ISO 12098 connector. This means that a wire must be installed to connect the 11th pin to the FM device. The place and method of installing the wire depends highly on the cabins' structure and personal preferences. There are several basic possible ways to install the wire:

- Wire is installed along existing wires going under the cabin;
- Wire is installed along existing wires going from the ISO 12098 connector;
- Wire is installed on the sides of the cabin – not recommended.

Depending on the way the wire will be installed, it is important to evaluate possible mechanical or elemental impact on the wire and pick the right insulation type and wire diameter. Generally it is recommended to use wires similar to the ones used in the 1-Wire temperature sensor, the wire core should be no less than 0.5mm² thick.

The connection schematic is identical for both Scania and Renault manufacturers.

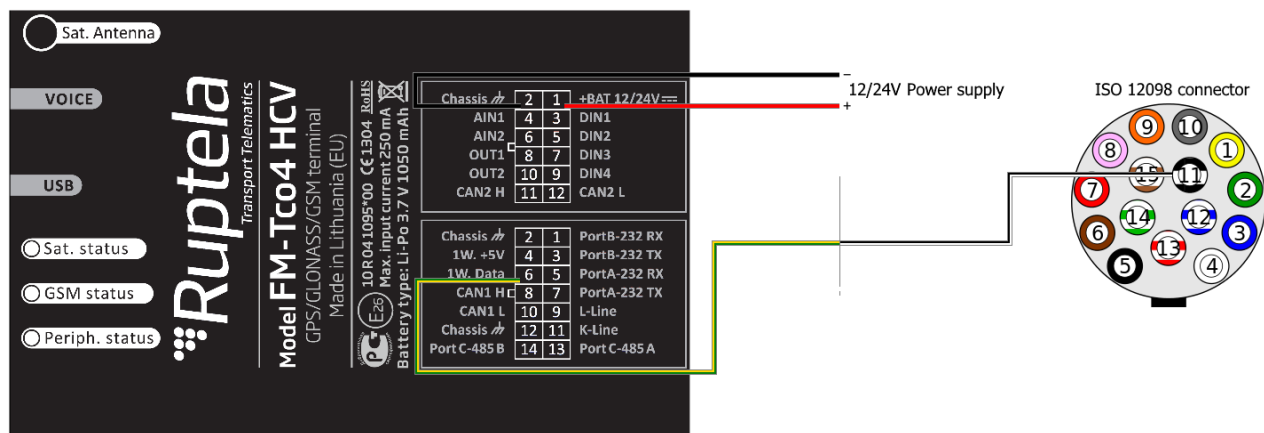

From the FM device side
1-Wire Data

From the ISO12098 connector side
Black/White – 1-Wire data from the temperature sensor

1-Wire temperature sensor configuration

For the temperature sensor to work as an identifier, it must be first properly configured. Start up your FM device (in truck) configurator and follow the steps provided:

1. In the main configurator window select your FM device model.
2. In the **IO events** sections, click the **Options** buttons. This will open a new window called **IO settings**.
3. Select an empty slot in which the temperature sensor parameter will be enabled.
4. In the **ID** drop-down list, select *Temperature sensor0 ID*.
5. Tick the **Enable** checkbox to activate and save the parameter in the selected slot.
6. Close the **IO settings** window and send the configuration to your FM device.

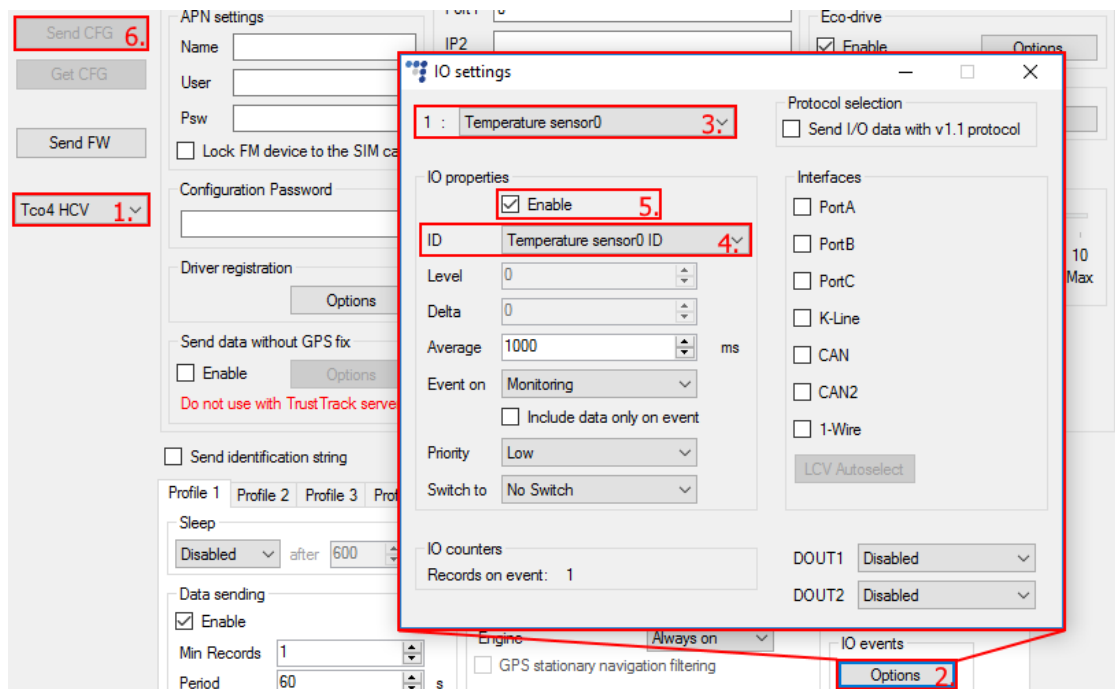

This part of the configuration enables and activates the temperature sensor itself, to further use it as an identifier, you must login to TrustTrack and continue the configuration there.

Note

The previously explained configuration settings work only if one temperature sensor is connected, if several temperature sensors are used, all of them must be marked. This process is described in the "1-Wire temperature sensor connection and configuration" document, available [here](#). Temperature sensor marking requires the power wire to be connected to the sensor.

Configuring the temperature sensor in TrustTrack

Before continuing to the TrustTrack system, make sure both FM devices are connected, the temperature sensor is connected to the FM device in the truck and the trailer is attached to the truck. The FM device installed in the trailer must be configured as *Trailer* in TrustTrack object settings. Turn on the ignition to power the devices, so they can start sending records to the server.

Login to TrustTrack and open the **Fleet status** panel. Select your trailer and open the **History** panel. In the **History** panel, pick the approximate time period, when the device started sending data with the temperature sensor already attached, and click the **Analyze by coordinates** button.

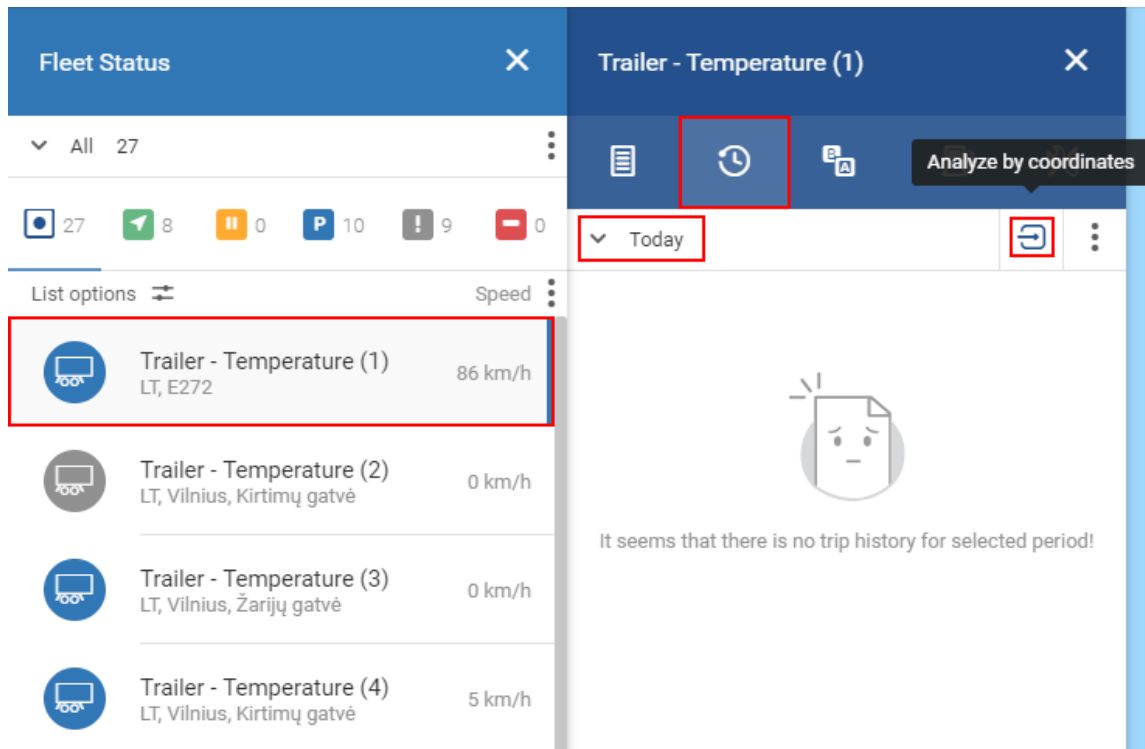

This will open the analysis by coordinates window. Click the .xls icon in the top right corner. This will export an .xls file with raw data.

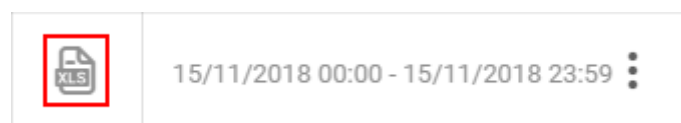

In the raw data file, locate the **Temperature sensor 0 ID** column.

Y	Z	AA	AB	AC	AD
Temperature Sensor 0	Speed	Operator	Movement	HDOP	Temperature Sensor 0 ID
8,5 °C	#####	24601	1	0,5	28158C1407000008
8,5 °C	#####	24601	1	0,5	28158C1407000008
8,5 °C	#####	24601	1	0,5	28158C1407000008
8,6 °C	#####	24601	1	0,5	28158C1407000008
8,5 °C	#####	24601	1	0,5	28158C1407000008
8,6 °C	#####	24601	1	0,6	28158C1407000008
8,6 °C	0,0 km/h	24601	0	0,8	28158C1407000008
8,6 °C	5,0 km/h	24601	0	0,8	28158C1407000008

Copy the displayed ID of your temperature sensor. Return to the **Fleet status** panel and select your trailer. Open the **Summary** panel and click the **Trailer details** button at the bottom of the panel.

The screenshot shows the Ruptela interface. On the left, the 'Fleet Status' panel displays a list of trailers. The entry 'Trailer - Temperature (1) LT, Vilnius, Gariūnų gatvė' is highlighted with a red box. On the right, the 'Trailer - Temperature (1)' summary panel is open. It shows the location 'Gariūnų gatvė, 55, Vilnius, Vilniaus apskritis, 02300, Lithuania' and the district 'Vilnius district'. The trailer is identified as 'Trailer - Temperature (1)' with a 'Premium' plan. The current status is 'Ignition off', and the state duration is '191 days 2 h 32 min'. The last signal sync is 'a few seconds ago'. At the bottom of the summary panel, the 'Trailer details' button is highlighted with a red box.

Enter the copied temperature sensor ID in the **Trailer ID** field. Fill in any other fields you need. Do not forget to click the **Save** button. The trailer will now be assigned and will be displayed in the TrustTrack system.

Details

Trailer title <input type="text" value="Trailer - Temperature (1)"/>		Notes <input type="text"/>
VIN <input type="text"/>	Plate number <input type="text"/>	
Make <input type="text"/>	Model <input type="text"/>	
Trailer ID <input type="text" value="28158C1407000008"/>		
Year <input type="text" value=""/>		
Payment plan Premium		Mileage correction 165,160.34 km
<input type="button" value="Save"/> <input type="button" value="Close"/>		